

Chromalox®

Installation, Operation and RENEWAL PARTS IDENTIFICATION

SERVICE REFERENCE

DIVISION 4	SECTION CHTV
SALES REFERENCE	PQ431
161-058058-001	
DATE	JULY, 1983

Type CHTV Horizontal Vaporizers for Dowtherm®, Therminol® and Other Organic Fluids (Temperatures to 750°F at 150 psi, 15 kW thru 300 kW)

Manufacturing Data -	System Model Number and Rating	System Serial Number
	Customer's Name	Customer's Order Number
	National Board Number	Date

Specifications & Dimensions

kW	BTUH	Ampere*		Model Number				Operating Volume	Dimensions (In.)			Weight (Lbs.)
		240V	480V	Standard NEMA I	Oil & Dust Tight NEMA XII	Weather-resistant NEMA IV	Explosion-resistant Class1, Group D		L	W	H	w/o Controls
15	51,180	36.0	18.0	CHTV-316-15	CHTVO-316-15	CHTVW-316-15	CHTVX-316-15	15.7	80	36	50	600
20	68,240	48.1	24.0	CHTV-316-20	CHTVO-316-20	CHTVW-316-20	CHTVX-316-20	19.4	94	36	50	700
25	78,500	60.1	30.1	CHTV-316-25	CHTVO-316-25	CHTVW-316-25	CHTVX-316-25	23.6	110	36	50	825
30	102,360	72.2	36.1	CHTV-316-30	CHTVO-316-30	CHTVW-316-30	CHTVX-316-30	27.2	124	36	50	925
40	136,480	96.2	48.1	CHTV-316-40	CHTVO-316-40	CHTVW-316-40	CHTVX-316-40	35.6	156	36	50	1175
50	157,000	120.3	60.1	CHTV-316-50	CHTVO-316-50	CHTVW-316-50	CHTVX-316-50	43.5	186	36	50	1400
40	136,480	96.2	48.1	CHTV-624-40	CHTVO-624-40	CHTVW-624-40	CHTVX-624-40	75.0	95	48	60	1200
50	157,000	120.3	60.1	CHTV-624-50	CHTVO-624-50	CHTVW-624-50	CHTVX-624-50	106.0	111	48	60	1450
60	204,720	144.3	72.2	CHTV-624-60	CHTVO-624-60	CHTVW-624-60	CHTVX-624-60	137.0	125	48	60	1600
75	235,500	180.4	90.2	CHTV-624-75	CHTVO-624-75	CHTVW-624-75	CHTVX-624-75	168.0	149	48	60	1900
100	341,200	240.6	120.3	CHTV-624-100	CHTVO-624-100	CHTVW-624-100	CHTVX-624-100	218.0	187	48	60	2350
100	341,200	240.6	120.3	CHTV-1230-100	CHTVO-1230-100	CHTVW-1230-100	CHTVX-1230-100	218.0	111	54	66	2400
125	392,500	-	150.4	CHTV-1230-125	CHTVO-1230-125	CHTVW-1230-125	CHTVX-1230-125	222.0	129	54	66	2700
150	511,800	-	180.4	CHTV-1230-150	CHTVO-1230-150	CHTVW-1230-150	CHTVX-1230-150	263.0	149	54	66	3100
175	549,500	-	210.5	CHTV-1230-175	CHTVO-1230-175	CHTVW-1230-175	CHTVX-1230-175	300.0	167	54	66	3500
200	682,400	-	240.6	CHTV-1230-200	CHTVO-1230-200	CHTVW-1230-200	CHTVX-1230-200	340.0	187	54	66	3950
225	767,700	-	271.0	CHTV-1836-225	CHTVO-1836-225	CHTVW-1836-225	CHTVX-1836-225	379.0	149	60	72	4600
250	853,000	-	301.0	CHTV-1836-250	CHTVO-1836-250	CHTVW-1836-250	CHTVX-1836-250	417.0	162	60	72	5200
275	938,300	-	331.0	CHTV-1836-275	CHTVO-1836-275	CHTVW-1836-275	CHTVX-1836-275	455.0	175	60	72	5600
300	1,023,600	-	361.0	CHTV-1836-300	CHTVO-1836-300	CHTVW-1836-300	CHTVX-1836-300	490.0	187	60	72	6000

*All amperes based on 3ph 60 cycle power.

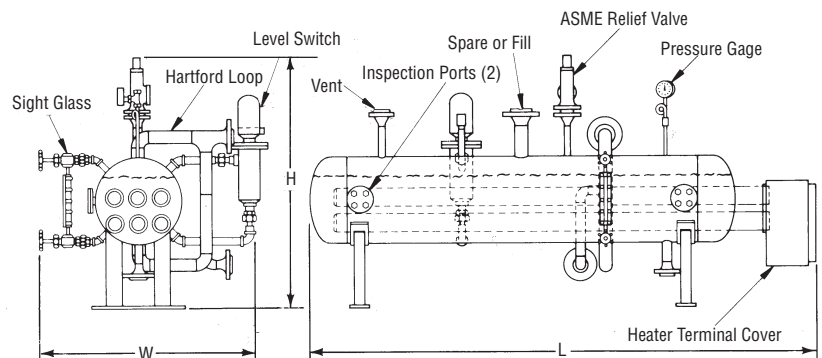
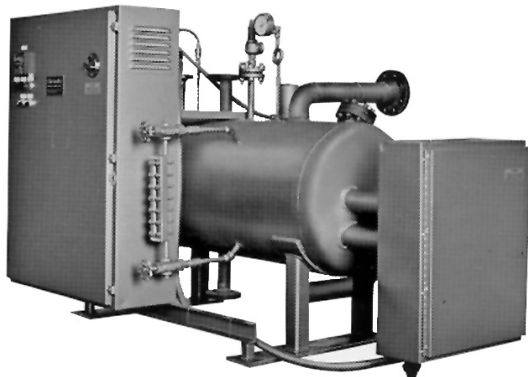

GENERAL

The Chromalox Horizontal Electric Vaporizer is a thoroughly engineered pre-tested package, designed to give years of service, virtually maintenance free if properly installed. The CHTV series is ASME certified for 150 PSI at 750°F and is available in four models, each with basic features that comply with the National Electrical Code. Model CHTV has general-purpose NEMA I construction and can be used where no hazards exist. Model CHTVO is oil and dust tight as specified by NEMA XII standards. Model CHTVW can be used where weather-resistant construction is required and is constructed according to NEMA IV specifications.

Model CHTVX, Class 1, Group D, Division 1 is explosion-resistant and is constructed to operate in hazardous or explosive areas. **WARNING:** Vessel and pipe surfaces could achieve temperatures higher than allowed for Class 1, Group D, Division 1 hazardous areas. Common to all four models: OCE (open coil element) type heating elements installed in 3", schedule 40 seamless carbon steel pipes; watt density on the outside of the pipe surface is 10 watts per square inch; elements are removable without draining the fluid in the vaporizer; requirements 208, 240, 480 and 550 volt, 3 phase, 60 cycle, 15 to 300kW.

INSTALLATION

CAUTION: This vaporizer is not for use with water or ethylene glycol and water mixtures as the heat transfer media. Check with your local Chromalox Sales and Application Engineer to be sure that you are using an accepted heat transfer media in this vaporizer or consult PQ301.

Note: When installing the vaporizer, allow a minimum of 3 feet for removing heating element if, and when, necessary.

HYDRAULIC OR MECHANICAL:

Note: The CHTVW vaporizer should be mounted so that the control box does not fall in direct sunlight.

The bed plate should be mounted on solid foundation, preferably level.

The pipe lines from the Chromalox vaporizer to the process should be the same size as the vaporizer's piping connections. All piping should be arranged so that the vaporizer is not subject to extreme nozzle loading due to thermal expansion and contraction of pipe lines. If these instructions are not followed, cracks could develop in the vaporizer where the inlet and outlet nozzles are attached.

1. The piping of the entire system should be arranged to minimize pockets where air may be trapped. Manual air vents or bleeder valves should be provided at all high points in the system and every time the flow of the condensate has to drop.

2. Condensate return systems:

A. Gravity return type: The simplest and most easily operated type of vaporizer is one in which the condensate from the heating equipment is returned to the vaporizer by gravity, thus providing a system without moving parts. Such a system is possible if there is sufficient difference in elevation between the process and the vaporizer so the static liquid head will counter-balance all frictional losses in the vaporizer, vapor piping process and condensate return piping without flooding the heated equipment. See Figure 1 for a typical schematic piping diagram.

B. Pumped return type: Where there is insufficient difference in elevation between the vaporizer and the process, the condensate must be returned to the vaporizer by a pump.

Normally, these pumps are of the centrifugal type; however, positive displacement pump may also be used. See Figure 2 for a typical schematic piping diagram.

3. **Hartford Loop** – In gravity return systems a Hartford Loop should be incorporated where the condensate is returned to any point below the desired liquid level of the vaporizer.

A Hartford Loop consists of a line without valves outside of the vaporizer connecting the vapor outlet and the condensate inlet. The condensate return line is connected to the vapor-condensate line or loop at the same elevation as the lowest permissible level in the vaporizer. Thus, a vacuum in the heated equipment can then pull liquid from the vaporizer (or a closed valve in the vapor line can force liquid from the vaporizer) only until the level in the vaporizer falls to the level of this connection. Also, the resultant liquid hammering will give warning that the liquid level in the vaporizer is too low. (See Figure 1 below.)

4. **Note:** All flange connections should be checked and tightened if necessary. These sometimes loosen during transit.

ELECTRIC:

kW	Volts	Control Box Size			No. Circuits	Control Accomplished By
		H	L	D		
15 Thru 30	240 or 480	30	24	8	1	1 Pressure Control with 1 Switch
40 Thru 60	240 or 480	30	30	8	2	1 Pressure Control with 2 Switches
75 Thru 100	240 or 480	42	30	8	3	1 Pressure Control with 3 Switches
125 Thru 150	480	48	36	8	4	1 Proportional Pressure Control with 4-step electronic stepper
175 Thru 300	480	60	36	8	6	1 Proportional Pressure Control with 6-step electronic stepper

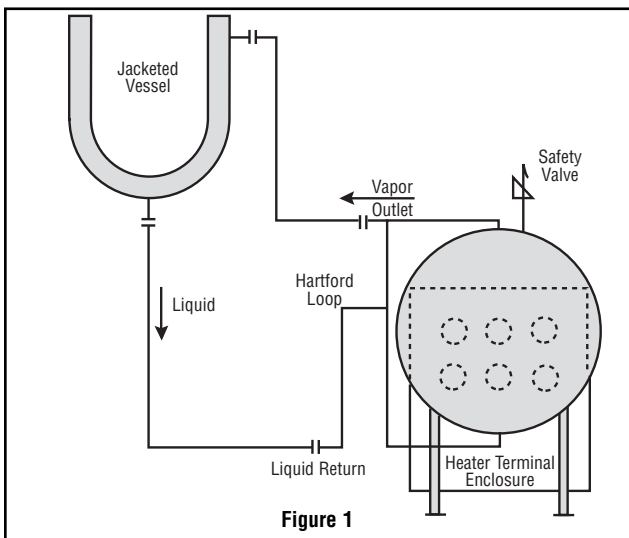

Figure 1

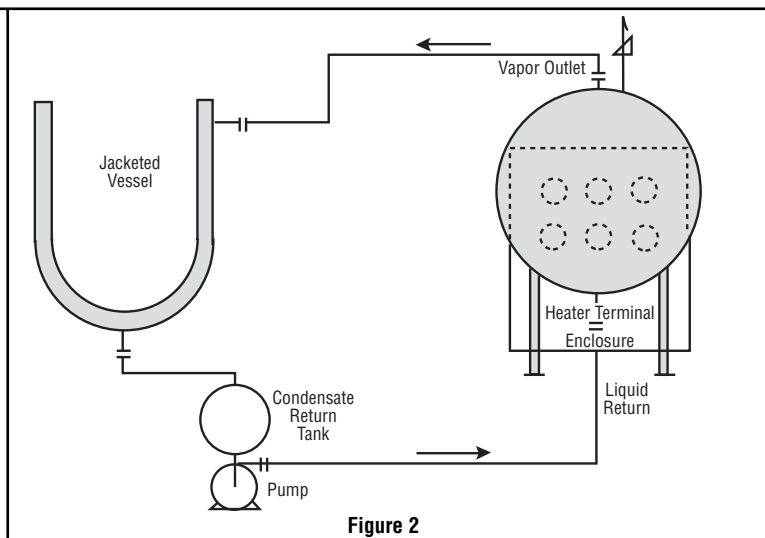

Figure 2

INSTALLATION

CAUTION: Hazard of Electric Shock. The vaporizer must be grounded using the grounding means provided in the heater terminal box and in the control box, and employ wiring in accordance with the National Electrical Code.

1. The vaporizer is normally supplied one of three different ways:
 - A. Without controls as they are going to be provided by the customer. The customer will have to wire from his supplied controls to the level or float switch on the vessel, and to the heater terminal blocks and the ground lug in the heater terminal enclosure.
 - B. With controls supplied, but mounted remotely by the user. The customer will have to wire from remote controls to the level or float switch on the vessel, and to the heater terminal

blocks and the ground lug in the heater terminal enclosure.

- C. With all controls mounted on the same skid with the hydraulic or mechanical part of the vaporizer. The unit is completely wired. The only wiring necessary is to terminals L1, L2 and L3 on the main circuit breaker and the grounding lug in the control panel.

2. **Note:** All electrical connections should be checked and tightened if necessary. These sometimes loosen in transit.

CAUTION: Hazard of Electric Shock. Disconnect all power before servicing the vaporizer.

WIRING DIAGRAMS

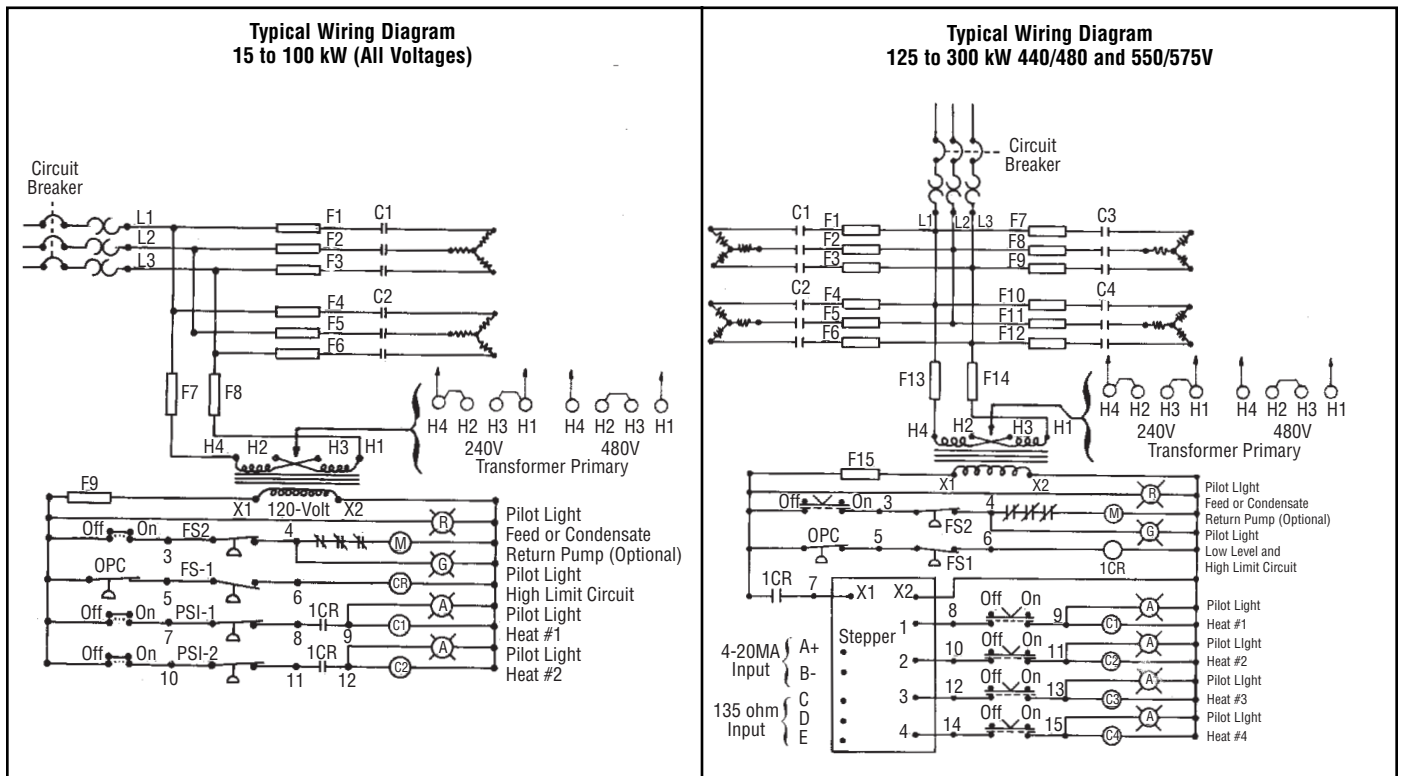

OPERATION

CAUTION: To avoid possible damage to the heaters, do not energize the heaters until the vaporizer is filled with fluid.

1. The filling of the Chromalox CHTV type horizontal vaporizer is accomplished in one of two ways:
 - A. On vaporizers with gravity return type condensate return systems, the filling is done simply by pouring the heat transfer or other organic media into the vaporizer shell using the spare or fill nozzle and, while the filling is taking place, bleeding the displaced air from the vent.
 - B. On vaporizers that use pump condensate return systems or on systems where the condensate is not returned, the filling would be done by first filling the condensate return tank or supply or reservoir tank and then energizing the condensate return or supply pump. While the vaporizer vessel is being filled, the vent nozzle should be opening for bleeding out the air.
2. Set the thermostat at 220°F and/or the controlling pressure switch at its equivalent.
3. To energize the heaters, turn the "on-off" selector switch to the "on" position. The heaters are interlocked with the level or

float switch located on the vessel, so that the heating element will shut off automatically in case of a low liquid level.

4. Operate the vaporizer until 220°F is reached. Periodically open the bleed valves to remove air from the system. At 220°F any moisture that has been trapped in the system will flash into steam and can be bled off through the bleeder valves.

WARNING: Avoid having the heat transfer fluid or the fluid to be vaporized spilled or leaked into the pipeline or vessel insulation as it has been found that spontaneous ignition of some of these fluids may result at elevated temperatures.

5. After the vaporizer has been completely charged and free of steam pockets, set the controlling pressure switch or thermostat to the pressure or temperature point where the fluid will vaporize.
6. Operate the vaporizer until this set point is reached. Periodically open the bleeder valves to remove air from the system.
7. After the system is completely free of air, set the controlling pressure switch or thermostat to the desired operating point.

MAINTENANCE

CAUTION: Hazard of Severe Shock. Disconnect all power to heater before servicing or replacing heaters.

1. Heaters should be checked periodically for coatings and corrosion and cleaned if necessary.
2. The tank should be checked regularly for sediment around the heater as sediment can act as an insulator and shorten heater life.
3. Remove any accumulated sludge deposits from heater and from tank.
4. Check for loose terminal connections and tighten if necessary.

RENEWAL PARTS IDENTIFICATION

Vaporizer Model No. CHTV, CHTVO, CHTVW or CHTVX	Heating Element Part Number	
	240V	480V
316-15	063-122121-001	063-122121-002
316-20	063-122121-003	063-122121-004
316-25	063-122121-005	063-122121-006
316-30	063-122121-007	063-122121-008
316-40	063-122121-013	063-122121-014
316-50	063-122121-017	063-122121-018
624-40	063-122121-003	063-122121-004
624-50	063-122121-005	063-122121-006
624-60	063-122121-007	063-122121-008
624-75	063-122121-011	063-122121-012
624-100	063-122121-017	063-122121-018
1230-100	063-122121-005	063-122121-006
1230-125	063-122121-009	063-122121-010
1230-150	063-122121-011	063-122121-012
1230-175	063-122121-015	063-122121-016
1230-200	063-122121-017	063-122121-018
1836-225	063-122121-011	063-122121-012
1836-250	_____	063-122121-019
1836-250	_____	063-122121-020
1836-300	063-122121-017	063-122121-018

Limited Warranty:

Please refer to the Chromalox limited warranty applicable to this product at
<http://www.chromalox.com/customer-service/policies/termsforsale.aspx>.

Chromalox®
PRECISION HEAT AND CONTROL

2150 N. RULON WHITE BLVD., OGDEN, UT 84404
 Phone: 1-800-368-2493 www.chromalox.com